

 **oleotec**  
COMPONENTI OLEODINAMICI



VISION TO TECHNOLOGY

► MCS - abbreviazione di "MINI CONTROL SYSTEM" definisce una gamma completa di raccordi miniaturizzati per oleodinamica, miniprese di pressione e relativi accessori. MCS offre un sistema semplice ed economico per il controllo delle pressioni nei sistemi idraulici, grazie al quale è possibile eliminare l'impiego di manometri fissi ed esclusori montati permanentemente sul sistema, riducendo così sia i costi iniziali che quelli per la sostituzione dei manometri danneggiati da anomalie del sistema o da agenti esterni.

► E' possibile installare le miniprese MCS in qualsiasi punto del sistema idraulico in cui occorre monitorare la pressione e, in caso di postazioni lontane o difficili da raggiungere, una minipresa MCS passaparete e un miniflessibile MCS consentono di portare la pressione ad un pannello centrale facilitandone il controllo. Il miniflessibile è così piccolo e flessibile da poter essere installato come un normale cavo elettrico.

► Un altro vantaggio di MCS è quello di poter controllare la pressione mentre il sistema idraulico è a pieno regime; i raccordi e il miniflessibile

tollerano una pressione massima di lavoro di 630bar. Grazie al loro design, è possibile unire la minipresa al miniflessibile avvitandoli insieme semplicemente con due dita, senza dover utilizzare strumenti particolari e senza rischio di trafiletti mentre il sistema idraulico è in funzione; la connessione fa tenuta automaticamente e non si allenta in seguito a vibrazioni o picchi di pressione.

► MCS offre inoltre svariati tipi di terminali in grado di adattarsi alle miniprese di altri costruttori; possono ser-

vire anche per ottenere dei campioni di fluido da diversi punti del sistema idraulico oppure per spurgare il sistema oleodinamico dall'aria.

► Il "MINI CONTROL SYSTEM" è talmente versatile da essere utilizzato al posto dei tubi rigidi per collegamento manometri, pressostati, trasduttori di pressione, linee di pilotaggio ecc. Attutisce i picchi di pressione e grazie all'effetto capillare del miniflessibile impedisce che le vibrazioni raggiungano gli strumenti.



► MCS - short for mini control system - defines a complete range of miniature fittings, check couplings and accessories. MCS offers a simple, inexpensive means to check pressure in hydraulic systems. Permanently mounted pressure gauges and shut-off valves are no more necessary, thereby reducing initial costs. Replacement costs due to gauges broken by system problems or external damages are also eliminated.

► MCS check couplings can be installed at any point of the hydraulic system where pressure is to be monitored. For remote or hard-to-reach locations, an MCS bulkhead coupling and an MCS micro-bore hose bring pressure to a central panel thus simplifying its control. The micro-bore hose is so small and flexible that it can be installed like electrical wiring.

► Pressure can be checked while hydraulic systems are at full pressure. Micro test fittings and micro-bore hoses can bear a max. working pressure of 630 bar. Thanks to their design, both the connector and the micro hose coupling can be joined under pressure by screwing the coupling with two fingers without any tools and any leakage; the connection is self-sealing and will not loosen under vibration or pressure peaks.

► MCS offers optional hose ends to adapt to many other test couplings from other suppliers. Besides, they can be used for obtaining fluid samples from various points in hydraulic systems or as an air bleed device.

► The "Mini Control System" is versatile enough to be used instead of rigid pipes for pressure gauges, pressure

switches, pressure transducers, pilot lines, etc.

It dampens pressure peaks and prevents vibration from reaching the instruments, thanks to the micro hose's capillary effect.

#### Dati tecnici

Norma di riferimento: ISO 15171-2 08/2000  
 Pressione di lavoro: 630 bar max.  
 Pressione di scoppio: >2520 bar

#### ► Applicazioni

- Controllo pressione in circuiti idraulici
- Lubrificazione
- Spurgo aria
- Prelievo campioni olio
- Microidraulica

#### ► Fluidi

- Olii idraulici e olii a base minerale
- Compatibilità con altri fluidi a richiesta

#### ► Materiale

- Corpo minipresa e cappuccio in Acciaio Trafil 9SMnPb28K
- Guarnizione anti vibrazione in BUNA N. (opzionale)
- Acciaio inox AISI 316 - DIN 14436: su richiesta

#### Temperatura di impiego:

##### ► con cappuccio di metallo

- con guarnizione in BUNA N.: -30°C a +120°C
- con guarnizione in VITON: -20°C a +200°C

##### ► con cappuccio in plastica

- -30°C a +100°C

#### ► Trattamento di finitura:

- Zincatura secondo
- ISO 2081 e 4520

#### Technical data

Reference norm: ISO 15171-2 08/2000  
 Working pressure: 630 bar max.  
 Burst pressure: >2520 bar

#### ► Applications

- Pressure check in hydraulic systems
- Lubrication
- Air bleeding
- Oil samples drawing
- Microhydraulics

#### ► Fluids

- Hydraulic oils and mineral-based oils
- Compatibility with other fluids: on request

#### ► Materials

- Test point's body and cap made of steel 9SMnPb28K
- Anti-vibration sealing made of BUNA N. (optional)
- Stainless steel AISI 316 - DIN 14436: on request

#### Working temperature:

##### ► with steel cap

- with sealing in BUNA N.: -30°C a +120°C
- with sealing in VITON: -20°C a +200°C

##### ► with plastic cap

- -30°C a +100°C

#### ► Finish treatment:

- Zinc-plating according to
- ISO 2081 e 4520

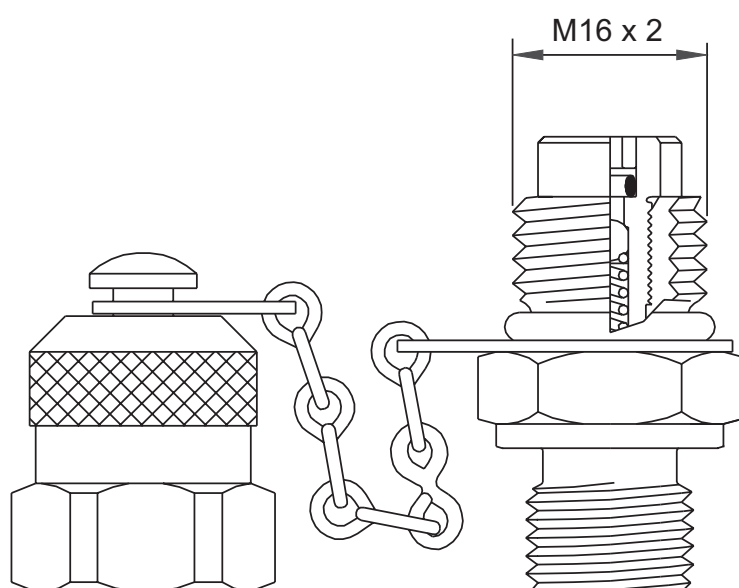

## Tipi di tenuta secondo DIN - ISO - ANSI - SAE - BS - JIS

### Sealing types according to DIN - ISO - ANSI - SAE - BS - JIS

#### FORM A

- ▶ Tenuta con guarnizione metallica
- ▶ sealing by metal ring

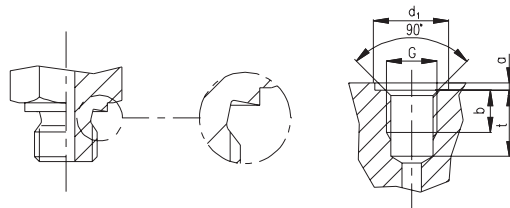

#### FORM A

DIN 3852

G	a	b	d <sub>1</sub>	t
M10x1	1	8	20	13,5
ISO 228 G1/4"	1,5	12	25	18,5

#### FORM B

- ▶ Tenuta meccanica
- ▶ Metal to metal sealing

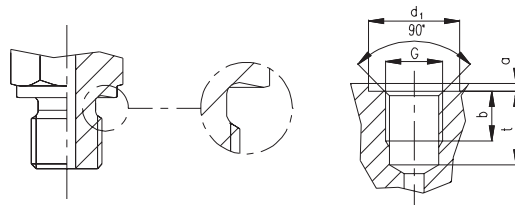

#### FORM B

DIN 3852 - ISO 1179-1

G	a	b	d <sub>1</sub>	t
M12x1,5	1,5	12	25	18,5
M14x1,5	1,5	12	25	18,5
M16x1,5	1,5	12	28	18,5
ISO 228 G1/8"	1	8	19	13
ISO 228 G1/4"	1,5	12	25	18,5

#### FORM C

- ▶ Tenuta sul filetto
- ▶ sealing by thread

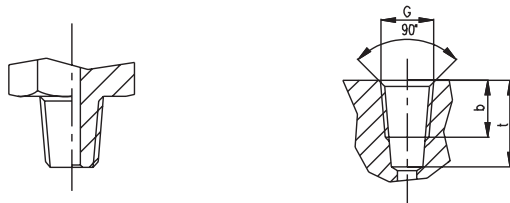

#### FORM C

DIN 3852

G	b	t
ISO 7/1 - R1/8"	5,5	9,5
ISO 7/1 - R1/4"	8,5	13,5
ISO 7/1 - R3/8"	8,5	13,5
M10x1	5,5	10,0

#### FORM C

ANSI/ASME B 1.20.1-1983

G	b	t
1/8" - 27 NPTF	-	11,6
1/4" - 18 NPTF	-	16,4
3/8" - 18 NPTF	-	17,4

#### FORM E

- ▶ Tenuta con guarnizione piana
- ▶ Sealing by fitted ring

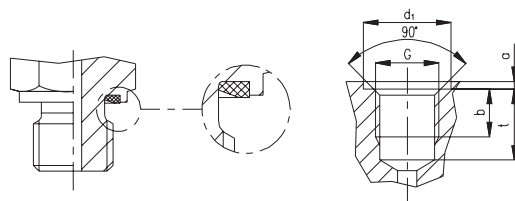

#### FORM E

DIN 3852 - ISO 1179-1

G	a	b	d <sub>1</sub>	t
M10x1	1	8	17	13,5
M12x1,5	1,5	12	20	18,5
M14x1,5	1,5	12	21,5	18,5
M16x1,5	1,5	12	24,5	18,5
ISO 228 G1/8"	1	8	17	13
ISO 228 G1/4"	1,5	12	20	18,5
ISO 228 G1/4"	2	12	24,5	18,5

#### FORM F

- ▶ Tenuta con guarnizione O-ring
- ▶ Sealing by O-ring

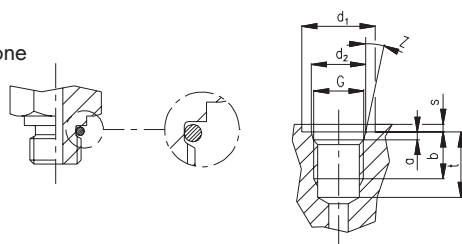

#### FORM F

ISO 6149-1

G	a	b	d <sub>1</sub>	d <sub>2</sub>	s	t	z
M8x1	1,6	10	17	9,1	1	10,5	12°
M10x1	1,6	10	19	11,1	1	11,5	12°
M14x1,5	2,4	11,5	21	15,8	1,5	14	12°

#### BS 5200

- ▶ Tenuta meccanica
- ▶ mechanical sealing

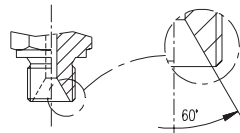

ISO 11296-1

7/16"-20 UNF	2,5	12	21	12,4	1,5	14	12°
1/2"-20 UNF	2,6	12	23	14	1,5	14	12°
9/16"-18 UNF	2,7	13	25	15,7	1,5	16	12°
3/4"-16 UNF	2,7	15	30	20,6	2,5	18	12°

JIS 2351

G 1/4"	2,5	12	/	15,6	/	18	15°
--------	-----	----	---	------	---	----	-----

## Minipresa di pressione avvvitabile - serie 620.01 Threaded check coupling - series 620.01

Minipresa con cappuccio di plastica  
Check-coupling with plastic cap

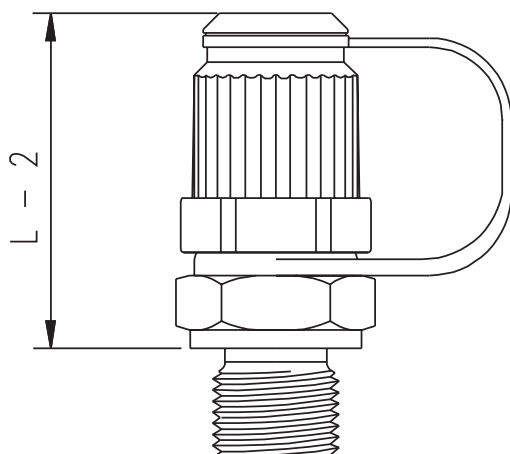

Minipresa con cappuccio di metallo  
Check-coupling with metal cap

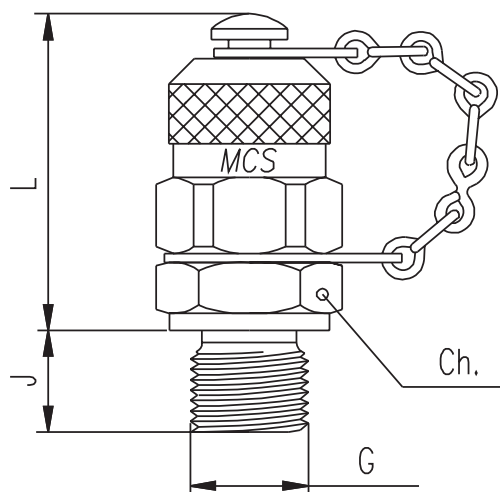

Filettatura Thread G	Tipo di tenuta Sealing type	p max.	Quote Dimensions			Con cappuccio di plastica With plastic cap	Con cappuccio di metallo With metal cap
			L mm	Ch. mm	J±0,2 mm		
M10 x 1	FORM A	400 bar	38	17	8	620.01.010.50	620.01.010.51
ISO228 G 1/4"	FORM A	400 bar	38	19	12	620.01.204.50	620.01.204.51
M12 x 1.5	FORM B	400 bar	38	17	12	620.01.012.10	620.01.012.11
M16 x 1.5	FORM B	400 bar	38	22	12	620.01.016.10	620.01.016.11
ISO228 G 1/8"	FORM B	400 bar	38	17	8	620.01.202.10	620.01.202.11
ISO228 G 1/4"	FORM B	400 bar	38	19	12	620.01.204.10	620.01.204.11
UNI 7707 M10x1	FORM C	400 bar	38	17	8	620.01.010.30	620.01.010.31
ISO 7/1 R 1/8"	FORM C	400 bar	36	17	8	620.01.202.30	620.01.202.31
ISO 7/1 R 1/4"	FORM C	630 bar	36	17	12	620.01.204.30	620.01.204.31
ISO 7/1 R 3/8"	FORM C	630 bar	36	22	12	620.01.206.30	620.01.206.31
1/8"-27 NPTF	FORM C	400 bar	36	17	9.5	620.01.302.30	620.01.302.31
1/4"-18 NPTF	FORM C	630 bar	36	17	14	620.01.304.30	620.01.304.31
3/8"-18 NPTF	FORM C	630 bar	36	22	14.2	620.01.306.30	620.01.306.31
M10 x 1	FORM E	400 bar	38	17	8	620.01.010.20	620.01.010.21
M12 x 1.5	FORM E	630 bar	38	17	12	620.01.012.20	620.01.012.21
M14 x 1.5	FORM E	630 bar	38	19	12	620.01.014.20	620.01.014.21
M16 x 1.5	FORM E	630 bar	38	22	12	620.01.016.20	620.01.016.21
ISO228 G 1/8"	FORM E	400 bar	38	17	8	620.01.202.20	620.01.202.21
ISO228 G 1/4"	FORM E	630 bar	38	19	12	620.01.204.20	620.01.204.21
ISO228 G 3/8"	FORM E	630 bar	38	22	12	620.01.206.20	620.01.206.21
M8 x 1	FORM F	250 bar	38	17	8.5	620.01.008.00	620.01.008.01
M10 x 1	FORM F	630 bar	38	17	9.5	620.01.010.00	620.01.010.01
M14 x 1.5	FORM F	630 bar	38	19	12	620.01.014.00	620.01.014.01
7/16"-20 UNF	FORM F	630 bar	38	17	11	620.01.404.00	620.01.404.01
* 1/2"-20 UNF	FORM F	630 bar	38	17	11	620.01.405.00	620.01.405.01
9/16"-18 UNF	FORM F	630 bar	38	19	12	620.01.406.00	620.01.406.01
3/4"-16 UNF	FORM F	630 bar	38	22	14	620.01.408.00	620.01.408.01
JIS 2531 G 1/4"	FORM F	630 bar	38	19	12	620.01.204.00	620.01.204.01
ISO228 G 1/4"	BS 5200	630 bar	38	19	12	620.01.204.80	620.01.204.81

\*Solo su richiesta \*Only on request

Esecuzioni speciali Special executions: M8 x 1 - M10 x 1.25 FORM F

## Minipresa di pressione con codolo 24° - serie 620.02

### Check-coupling with 24° sealing cone - series 620.02

Secondo DIN 3865  
According to DIN 3865

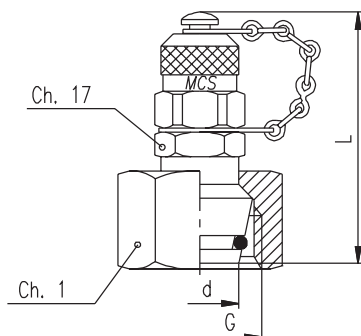

Serie Series	Filettatura Thread	p max.	Quote Dimensions		Con cappuccio di plastica With plastic cap	Con cappuccio di metallo With metal cap
			L mm	Ch. 1 mm		
L 6	M 12 x 1,5	315 bar	65	14	620.02.006.60	620.02.006.61
L 8	M 14 x 1,5	315 bar	66,5	17	620.02.008.60	620.02.008.61
L 10	M 16 x 1,5	315 bar	67	19	620.02.010.60	620.02.010.61
L 12	M 18 x 1,5	315 bar	58	22	620.02.012.60	620.02.012.61
L 15	M 22 x 1,5	315 bar	60	27	620.02.015.60	620.02.015.61
L 18	M 26 x 1,5	315 bar	61	32	620.02.018.60	620.02.018.61
L 22	M 30 x 2	160 bar	59,5	36	620.02.022.60	620.02.022.61
L 28	M 36 x 2	160 bar	66	41	620.02.028.60	620.02.028.61
L 35	M 45 x 2	160 bar	71,5	50	620.02.035.60	620.02.035.61
L 42	M 52 x 2	160 bar	74,5	60	620.02.042.60	620.02.042.61
S 6	M 14 x 1,5	630 bar	65	17	620.02.106.60	620.02.106.61
S 8	M 16 x 1,5	630 bar	66,5	19	620.02.108.60	620.02.108.61
S 10	M 18 x 1,5	630 bar	67	22	620.02.110.60	620.02.110.61
S 12	M 20 x 1,5	630 bar	58	24	620.02.112.60	620.02.112.61
S 14	M 22 x 1,5	630 bar	58,5	27	620.02.114.60	620.02.114.61
S 16	M 24 x 1,5	400 bar	61,5	30	620.02.116.60	620.02.116.61
S 20	M 30 x 2	400 bar	60,5	36	620.02.120.60	620.02.120.61
S 25	M 36 x 2	400 bar	65,5	46	620.02.125.60	620.02.125.61
S 30	M 42 x 2	400 bar	67,5	50	620.02.130.60	620.02.130.61
S 38	M 52 x 2	315 bar	69,5	60	620.02.138.60	620.02.138.61

## Minipresa di pressione con codolo liscio - serie 620.03

### Check-coupling with stand pipe - series 620.03

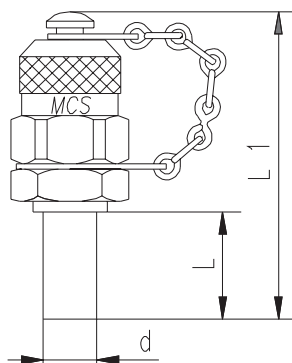

Serie Series	p max.	Quote Dimensions		Con cappuccio di plastica With plastic cap	Con cappuccio di metallo With metal cap
		L mm	L1 mm		
6	630 bar	20	57	620.03.006.50	620.03.006.51
8	630 bar	20	57	620.03.008.50	620.03.008.51
10	630 bar	20	57	620.03.010.50	620.03.010.51
12	630 bar	26	60	620.03.012.50	620.03.012.51

## Minipresa di pressione con giunzione diritta - serie 620.04 Check-coupling with straight tube connection - series 620.04

Secondo DIN 2353  
According to DIN 2353

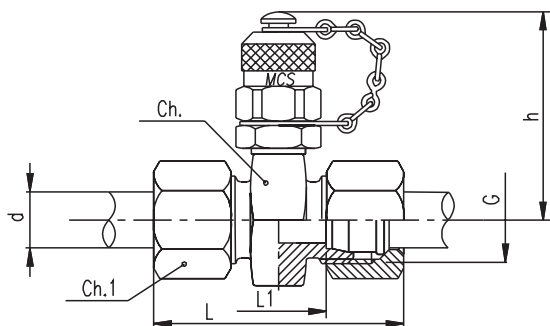

Serie Series	Filettatura Thread	p max.	Quote Dimensions					Con cappuccio di plastica	Con cappuccio di metallo
			L mm	L1 mm	Ch. mm	Ch.1 mm	h mm	With plastic cap	With metal cap
L 6	M 12 x 1,5	315 bar	54	20	19	14	45,5	620.04.006.50	620.04.006.51
L 8	M 14 x 1,5	315 bar	54	20	24	17	49	620.04.008.50	620.04.008.51
L 10	M 16 x 1,5	315 bar	59	22	22	19	48	620.04.010.50	620.04.010.51
L 12	M 18 x 1,5	315 bar	59	22	24	22	49	620.04.012.50	620.04.012.51
L 15	M 22 x 1,5	315 bar	64	25	27	27	50,5	620.04.015.50	620.04.015.51
L 18	M 26 x 1,5	160 bar	64	25	30	32	62	620.04.018.50	620.04.018.51
L 22	M 30 x 2	160 bar	71	25	32	36	53	620.04.022.50	620.04.022.51
L 28	M 36 x 2	160 bar	69	26	41	41	57,5	620.04.028.50	620.04.028.51
L 35	M 45 x 2	160 bar	80	25	50	50	60	620.04.035.50	620.04.035.51
L 42	M 52 x 2	160 bar	80	27	60	60	64,5	620.04.042.50	620.04.042.51
S 6	M 14 x 1,5	630 bar	58	24	19	17	46,5	620.04.106.50	620.04.106.51
S 8	M 16 x 1,5	630 bar	59	24	22	19	48	620.04.108.50	620.04.108.51
S 10	M 18 x 1,5	630 bar	63	24	22	22	48	620.04.110.50	620.04.110.51
S 12	M 20 x 1,5	630 bar	63	24	22	24	48	620.04.112.50	620.04.112.51
S 14	M 22 x 1,5	630 bar	71	24	24	27	49	620.04.114.50	620.04.114.51
S 16	M 24 x 1,5	400 bar	71	25,5	27	30	50,5	620.04.116.50	620.04.116.51
S 20	M 30 x 2	400 bar	78	25,5	36	36	55	620.04.120.50	620.04.120.51
S 25	M 36 x 2	400 bar	82	25,5	41	46	57,5	620.04.125.50	620.04.125.51
S 30	M 42 x 2	400 bar	91	27	46	50	60	620.04.130.50	620.04.130.51
S 38	M 52 x 2	315 bar	100	29	55	60	64,5	620.04.138.50	620.04.138.51

## Minipresa di pressione femmina girevole sede JIC 37° - serie 620.05 Check-coupling female swivel JIC 37°-SAE J514 - series 620.05

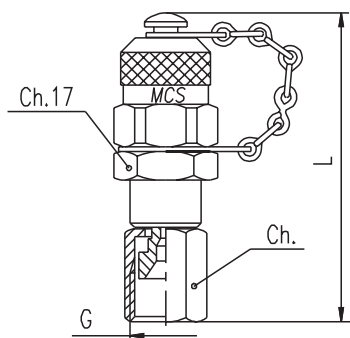

Filettatura Thread	p max.	Quote Dimensions		Con cappuccio di plastica	Con cappuccio di metallo
		L mm	Ch. mm	With plastic cap	With metal cap
7/16"-20 UNF	450 bar	64	14	620.05.404.00	620.05.404.01
1/2"-20 UNF	420 bar	67	17	620.05.405.00	620.05.405.01
9/16"-18 UNF	350 bar	69	19	620.05.406.00	620.05.406.01
3/4"-16 UNF	350 bar	71	22	620.05.408.00	620.05.408.01

## Minipresa di pressione passaparete - serie 620.06

### Bulkhead connection with check-coupling - series 620.06

Secondo DIN 3861  
According to DIN 3861

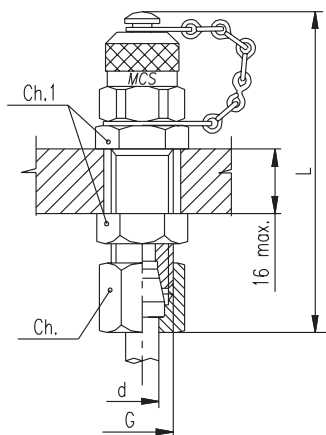

d mm	G	Filettatura Thread	p max. Acc. to DIN	Quote Dimensions			Con cappuccio di plastica	Con cappuccio di metallo
				Ch. mm	Ch.1 mm	L mm	With plastic cap	With metal cap
8	M 16 x 1,5	630 bar	19	22	82	620.06.108.50	620.06.108.51	
10	M 18 x 1,5	630 bar	22	24	84	620.06.110.50	620.06.110.51	

Secondo SAE J514  
According to SAE J514

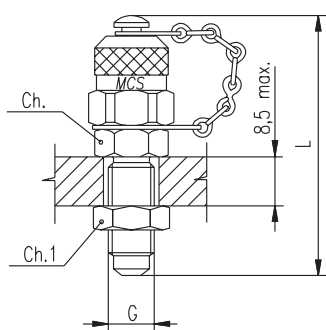

G	Filettatura Thread	p max.	Quote Dimensions			Con cappuccio di plastica	Con cappuccio di metallo
			Ch. mm	Ch.1 mm	L mm	With plastic cap	With metal cap
7/16"-20	JIC37°	450 bar	17	17	68	620.06.404.00	620.06.404.01

## Minipresa di pressione femmina girevole - serie 620.07

### Check-coupling female swivel - series 620.07

Secondo BS 5200  
According to BS 5200

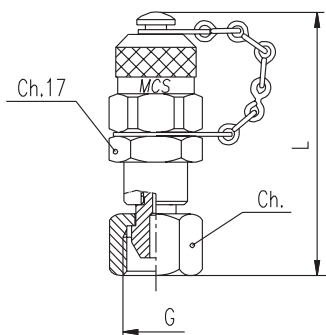

G	Filettatura Thread	p max.	Quote Dimensions		Con cappuccio di plastica	Con cappuccio di metallo
			L mm	Ch. mm	With plastic cap	With metal cap
ISO 228	G1/4"	630 bar	62	19	620.07.204.80	620.07.204.81



## Portamanometro passaparete - serie 620.08 Bulkhead pressure gauge connection - series 620.08

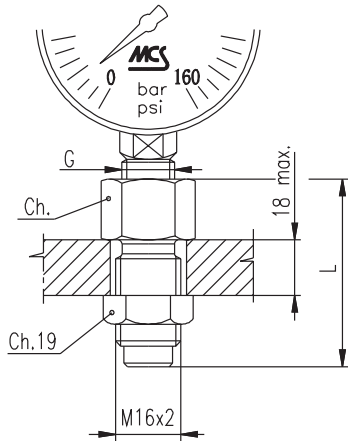

Filettatura Thread	p max.	Quote Dimensions		Passaggio libero Free flow	Con smorzatore With pressure damper
		Ch. mm	L mm		
*ISO228-G 1/4"	630 bar	19	50	620.08.204.00	620.08.204.00.1
*ISO228-G 1/2"	630 bar	27	58	620.08.208.00	620.08.208.00.1
1/4" NPTF	630 bar	19	50	620.08.304.00	620.08.304.00.1
1/2" NPTF	630 bar	27	58	620.08.308.00	620.08.308.00.1

## Portamanometro presa diretta - serie 620.09 Pressure gauge adapter - series 620.09

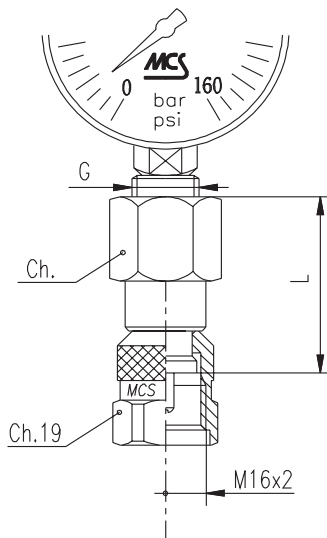

Filettatura Thread	p max.	Quote Dimens.		Passaggio libero Free flow	Con smorzatore With pressure damper
		Ch. mm	L mm		
*ISO228-G 1/4"	630 bar	19	34	620.09.204.00	620.09.204.00.1
*ISO228-G 1/2"	630 bar	27	39	620.09.208.00	620.09.208.00.1
1/4" NPTF	630 bar	19	34	620.09.304.00	620.09.304.00.1

## Portamanometro orientabile a gomito - serie 620.10 90° pressure gauge swivel connection - series 620.10

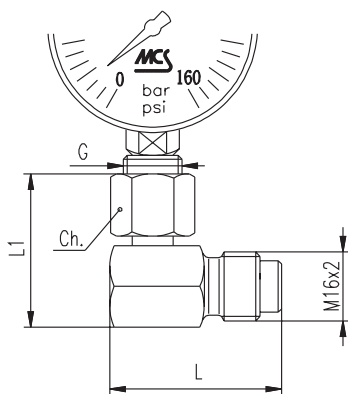

Filettatura Thread	p max.	Quote Dimensions			Passaggio libero Free flow	Con smorzatore With pressure damper
		Ch. mm	L mm	L1 mm		
*ISO228-G 1/4"	630 bar	17	40	40	620.10.204.00	620.10.204.00.1
*ISO228-G 1/2"	630 bar	27	40	42,7	620.10.208.00	620.10.208.00.1

\* Attacco manometro secondo DIN 16288  
\* Gauge connection acc. DIN 16288

## Minipresa passaparete - serie 620.11

### Bulkhead check-coupling - series 620.11

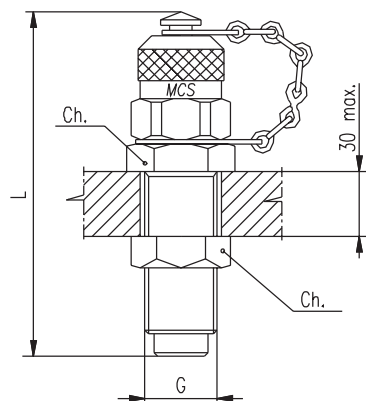

Filettatura Thread	p max.	Quote Dimensions		Con cappuccio di plastica With plastic cap	Con cappuccio di metallo With metal cap
		Ch. mm	L mm		
M 16 x 2	630 bar	19	81	620.11.000.70	620.11.000.71

## Minipresa passaparete (attacco a baionetta) - serie 620.12

### Bulkhead check-coupling (plug-in connection) - series 620.12

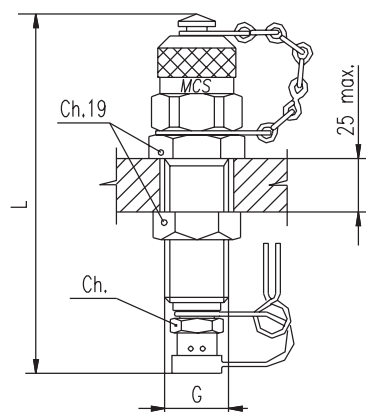

Filettatura Thread	p max.	Quote Dimensions		Con cappuccio di plastica With plastic cap	Con cappuccio di metallo With metal cap
		Ch. mm	L mm		
M 16 x 2	400 bar	12	87	620.12.000.70	620.12.000.71

## Giunzione a gomito - serie 620.13

### 90° elbow connection - series 620.13

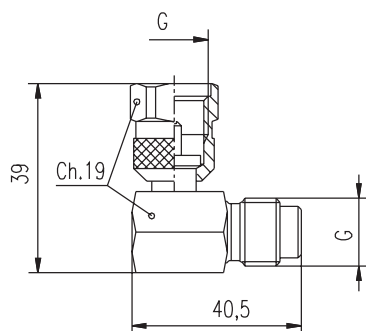

Filettatura Thread	p max.	Part. No.
M 16 x 2	630 bar	620.13.000.00

## Giunzione passaggio libero - serie 620.14

### Junction with free flow - series 620.14

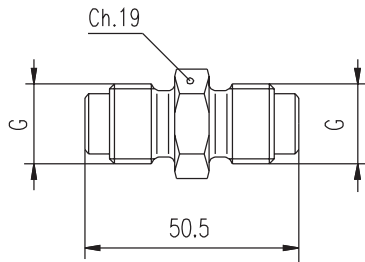

#### Filettatura Thread

**G**  
M 16 x 2

#### p max.

630 bar

#### Part. No.

620.14.162.00

## Giunzione con valvola di non ritorno - serie 620.15

### Junction with no-return valve - series 620.15

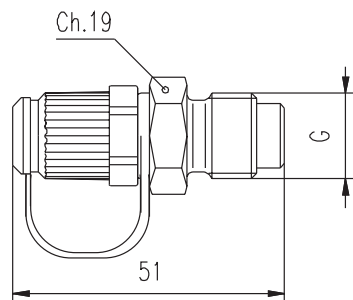

#### Filettatura Thread

**G**  
M 16 x 2

#### p max.

630 bar

#### Part. No.

620.15.162.00

## Minipresa di pressione con giunzione diritta 60° - serie 620.16

### Check coupling male - female swivel 60° - series 620.16

Secondo BS 5200  
According to BS 5200

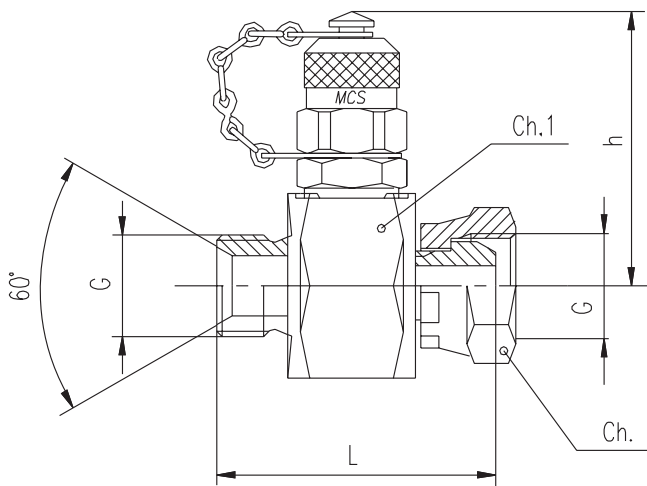

Filettatura Thread	p max.	Quote Dimensions					Con cappuccio di plastica With plastic cap	Con cappuccio di metallo With metal cap
		L mm	Ch. mm	Ch.1 mm	h mm			
ISO 228 G1/4"	400 bar	53	19 18	32 27	55 51,5	620.16.204.80	620.16.204.81	
ISO 228 G3/8"	400 bar	60	22 24	32 27	55 51,5	620.16.206.80	620.16.206.81	
ISO 228 G1/2"	400 bar	60	27	32 27	55 51,5	620.16.208.80	620.16.208.81	
ISO 228 G 3/4"	400 bar	68	32	32 32	55 54	620.16.212.80	620.16.212.81	
ISO 228 G 1"	345 bar	74	41	41 41	59,5	620.16.216.80	620.16.216.81	

## Minipresa di pressione inox - serie 625.xx Stainless steel check coupling - series 625.xx

INOX AISI 316 - DIN 1.4436

Stainless steel AISI 316 - DIN 1.4436

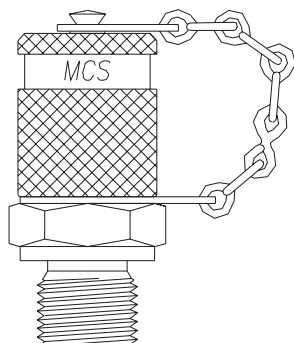

Modello Model  
625.01.XXX.XX

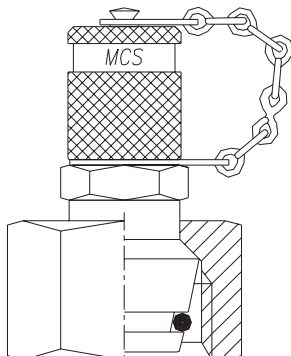

Modello Model  
625.02.XXX.XX

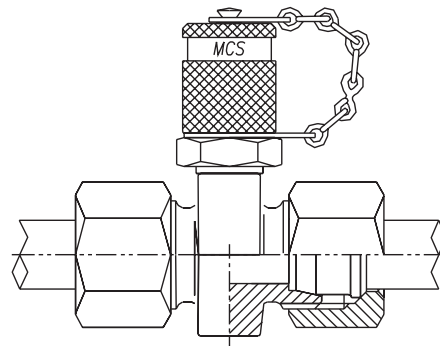

Modello Model  
625.04.XXX.XX

Per completare il codice vedere serie "620"  
See series "620" to complete code

## Minipresa di pressione S12.65x1.5 - serie 612.01 Check coupling S12.65x1.5 - series 612.01

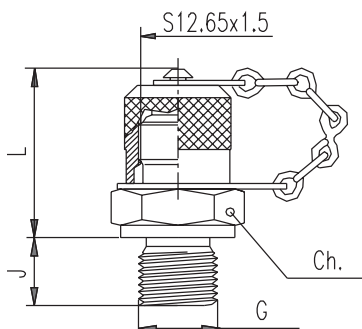

Filettatura Thread	Tipo di tenuta Sealing type	p max.	Quote Dimensions			Codice Part. No.
			L mm	Ch. mm	J <sub>±0.2</sub> mm	
M 8 x 1	Form F	250 bar	30	14	8.5	612.01.008.01*
M 10 x 1	Form F	630 bar	30	14	8.5	612.01.010.01*
ISO 228 G 1/4"	Form E	630 bar	32	19	10	612.01.204.20*
ISO 228 G 1/4"	Form E	630 bar	29	19	10	612.01.204.21*

\* .01-.21 Cappuccio in metallo / .01-.21 Metal cap

\* .20 Cappuccio in plastica / .20 Plastic cap

## Minipresa di pressione M16x1.5 - serie 615.01 Check coupling M16x1.5 - series 615.01

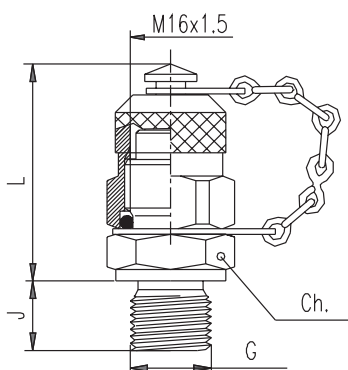

Filettatura Thread	Tipo di tenuta Sealing type	p max.	Quote Dimensions			Codice Part. No.
			L mm	Ch. mm	J <sub>±0.2</sub> mm	
ISO 228 G 1/4"	Form E	630 bar	38	19	10	615.01.204.21

► Tipo

VITON

EPDM

Senza cappuccio

- Minipresa con guarnizioni in VITON aggiungere: **.V**
- Minipresa con guarnizioni in EPDM aggiungere: **.EA**
- Minipresa senza cappuccio sostituire l'ultima cifra con **2**

► Esempio

620.01.204.21.**V**

620.01.204.21.**EA**

620.01.204.22

► Type

VITON

EPDM

Without cap

- For test point with VITON sealings add: **.V**
- For test point with EPDM sealings add: **.EA**
- For test point without cap replace the last number with **2**

► Example

620.01.204.21.**V**

620.01.204.21.**EA**

620.01.204.22

Accessori  
Accessories

Riduzioni  
Reducers

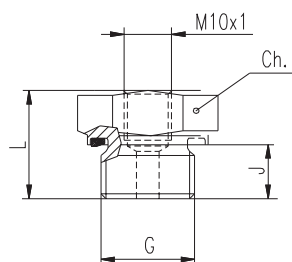

Filettatura

Tipi di tenuta  
Sealing type

p max. Quote

Thread

G			Dimensions			Part. No.
			Ch. mm	L mm	J mm	
ISO228-G 1/4"	FORM E	630 bar	19	25	12	630.01.204.20
ISO228-G 3/8"	FORM E	630 bar	22	25,5	15	630.01.206.20
ISO228-G 1/2"	FORM E	400 bar	27	25	14	630.01.208.20
ISO228-G 3/4"	FORM E	400 bar	32	27	16	630.01.212.20
ISO228-G 1"	FORM E	400 bar	41	29	18	630.01.216.20

Tronchetto a saldare  
Weld bosses

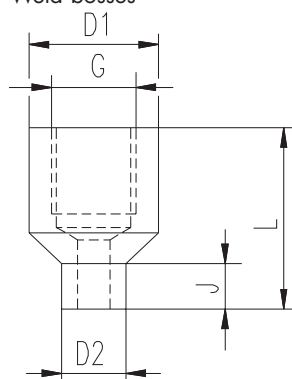

Filettatura

Quote

G	Dimensions		L mm	J mm	Part. No.
	D1 mm	D2 mm			
ISO228-G 1/4"	20	10	28	7	630.02.204.00
M 8 x 1	22	10	26	8	630.02.008.00

Cappuccio in plastica

Plastic dust cap  
Part. No. 630.03.620.00

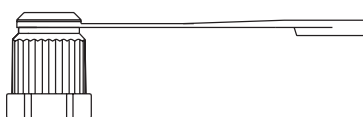

Cappuccio in acciaio

Steel dust cap  
Part. No. 630.03.162.03

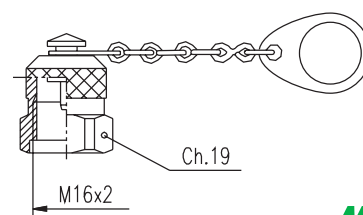

## Minipresa di pressione a baionetta - serie 400.01

### Plug-in check-coupling - series 400.01

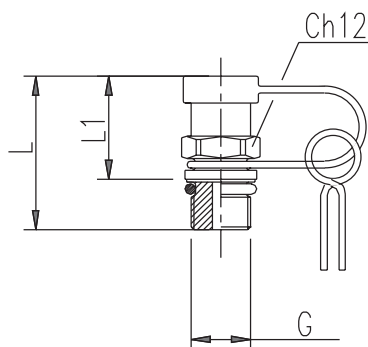

Filettatura Thread	Tipo di tenuta Sealing type	p max.	Quote Dimensions		Codice Part. No.	Senza valvola Without valve
			L mm	L1 mm		
<b>G</b>						
M 8 x 1	Form F	250 bar	28.5	19.5	400.01.008.00	400.01.008.01
M 10 x 1	Form F	400 bar	28.5	19.5	400.01.010.00	400.01.010.01

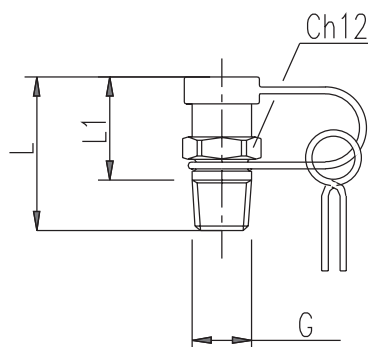

Filettatura Thread	Tipo di tenuta Sealing type	p max.	Quote Dimensions		Codice Part. No.	Senza valvola Without valve
			L mm	L1 mm		
<b>G</b>						
G 1/8"	Form C	400 bar	28.5	19.5	400.01.202.00	400.01.202.01
1/8"-27 NPTF	Form C	400 bar	30.5	19.5	400.01.302.00	400.01.302.01

## Cappuccio parapolvere

### Dust cap

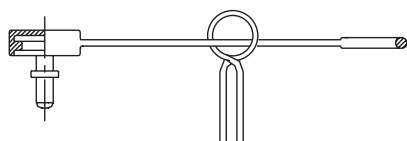

**Codice**  
**Code**  
630.03.400.00

**Minipresa a baionetta con codolo liscio**  
Plug-in check coupling with stand pipe

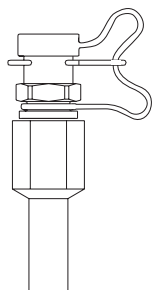

**Minipresa a baionetta con codolo 24°**  
Plug-in check coupling with 24° sealing cone

► **DIN 3865**

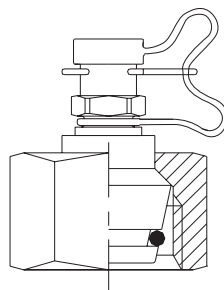

**Minipresa a baionetta passaparete**  
Bulkhead connection with plug-in check coupling

► **DIN 3861**

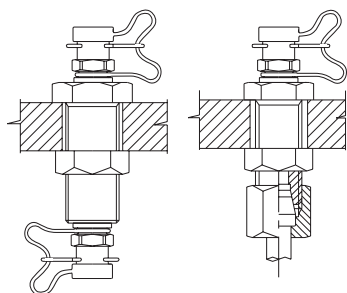

**Minipresa a baionetta femmina girevole**  
Plug-in check coupling with female swivel

► **BS 5200**

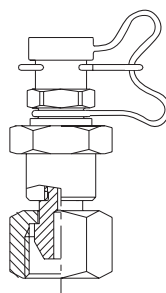

**Portamanometri**  
Pressure gauge connection

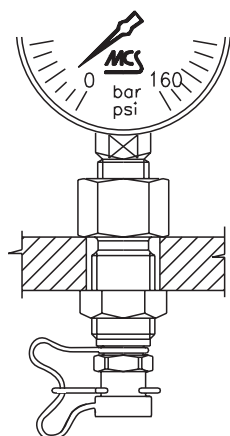

**Minipresa a baionetta con giunzione diritta**  
Plug-in check coupling with straight tube connection

► **DIN 2353**

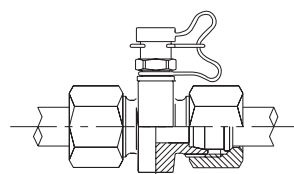

**Minipresa a baionetta con tenuta JIC**  
Plug-in check coupling with JIC seal

► **SAE J514**

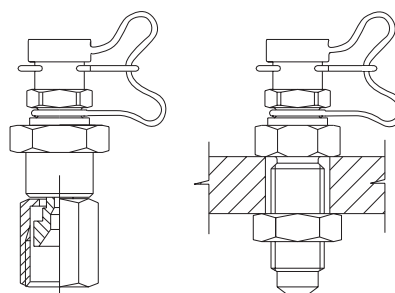





► **Caratteristiche Tecniche**

► **Technical Data**

	<b>Tubo Hose</b>		
	<b>6400</b>	<b>6500</b>	<b>6700</b>
diámetro interno inside diameter	2 mm ±0.1	4 mm ±0.2	4 mm ±0.2
diámetro esterno outside diameter	5 mm ±0.1	8 mm ±0.2	8 mm ±0.2
raggio minimo di curvatura minimum bend radius	20 mm	40 mm	40 mm
pressione max. di esercizio max. working pressure	630 bar	320 bar	500 bar
pressione di prova test pressure	950 bar	480 bar	750 bar
pressione min. di scoppio min. burst pressure	1900 bar	960 bar	1500 bar
temperatura di esercizio working temperature	-40°C + 100°C		
Temperatura/pressione di lavoro temperature/working pressure	-20°C +50°C : 100% ; >100°C : 77%		>80°C : 86%
anima interna tube	poliammide polyamide		
treccia di rinforzo braid	kevlar	fibra sintetica synthetic fibre	kevlar
copertura cover	poliammide polyamide		
peso al metro weight per meter	18 g	47 g	47 g

► **Perdita di carico**

► **Pressure drop**

**Tubo Hose 6400**

in un tubo lungo un metro con olio minerale con viscosità = 35 mm/sec.<sup>2</sup>

in a 1-meter-long hose with mineral oil with viscosity = 35 mm/sec.<sup>2</sup>

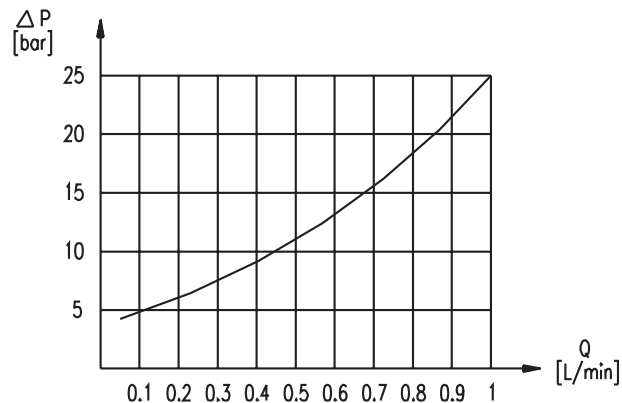

► **Esempio per l'ordinazione**

► **Order example**

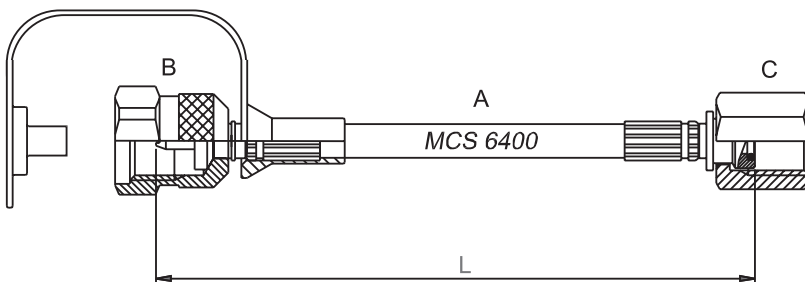

6400 - 10.162 - 50.204 - 2000 (mm)

A B C L

## Raccorderia per tubi flessibili MCS

### Fittings for MCS micro-hose

#### Ghiera Ferrule

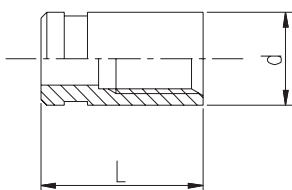

#### tubo tipo hose type

6400			6500 - 6700		
Part. No.	L	d	Part. No.	L	d
800.00.002.00	14	8	800.00.004.00	21	11
800.20.002.11*	14	8	/	/	/

\* = inox

\* = stainless steel

#### Raccordo avvitabile

##### Nut connection

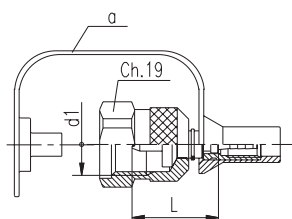

#### tubo tipo hose type

6400				6500 - 6700			
Part. No.	L	d1	p max.	Part. No.	L	d1	p max.
801.10.161.00	22	M16x1,5	630 bar	/	/	/	/
801.10.162.00	22	M16x2	630 bar	804.10.162.00	24	M16x2	500 bar
801.11.162.00*	22	M16x2	630 bar	/	/	/	/

α 800.02.000.02 Cappuccio parapolvere Dust protection cap

\* = inox

\* = stainless steel

#### Innesto a baionetta

##### Plug-in connection

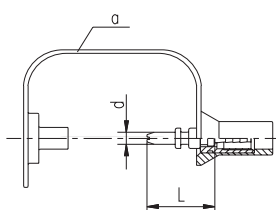

#### tubo tipo hose type

6400		6500 - 6700	
Part. No.	L	d	p max.
801.20.000.00	19	3,3	400 bar

α 800.02.000.01 Cappuccio parapolvere Dust protection cap

#### Raccordo a codolo

##### Standpipe

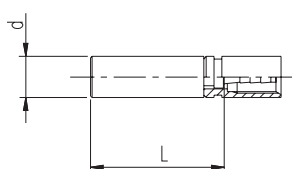

#### tubo tipo hose type

6400			6500 - 6700		
Part. No.	L	d	Part. No.	L	d
801.30.004.00	26	4	804.30.004.00	29	4
801.30.006.00	26	6	804.30.006.00	29	6
801.30.008.00	26	8	804.30.008.00	29	8

#### Raccordo a codolo con dado

##### Standpipe with nut

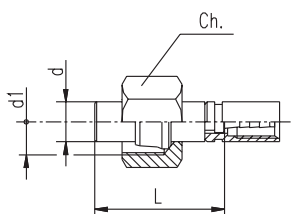

#### tubo tipo hose type

6400				6700		6500 - 6700			
Part. No.	L	d	p max.	Ch.	d1	Part. no	L	d	p max.
801.31.006.00	26	6	315 bar	14	M12x1,5	804.31.006.00	29	6	315 bar
801.32.006.00	26	6	630 bar	17	M14x1,5	804.32.006.00	29	6	500 bar
801.31.008.00	26	8	315 bar	17	M14x1,5	804.31.008.00	29	8	315 bar
801.32.006.00	26	8	630 bar	19	M16x1,5	804.32.008.00	29	8	500 bar

Raccordo a codolo a 90°  
90° elbow standpipe

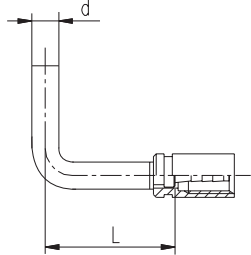

tubo tipo hose type

6400			6500 - 6700		
Part. No.	L	d	Part. No.	L	d
801.35.004.00	23	4	804.35.004.00	29	4
801.35.006.00	22	6	804.35.006.00	31	6
801.35.008.00	31	8	804.35.008.00	33	8

Raccordo a codolo 90° con dado  
Secondo DIN 2353  
90° elbow standpipe with nut  
According to DIN 2353

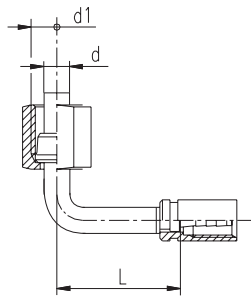

tubo tipo hose type 6400 -

6400			6500 - 6700		6500 - 6700	
Part. No.	L	d	p max.	Ch. d1	Part. no	p max.
801.36.006.00	28	6	315 bar	14 M12x1,5	804.36.006.00	315 bar
801.37.006.00	28	6	630 bar	17 M14x1,5	804.37.006.00	500 bar
801.36.008.00	30	8	315 bar	17 M14x1,5	804.36.008.00	315 bar
801.37.008.00	30	8	630 bar	19 M16x1,5	804.37.008.00	500 bar

Raccordo femmina metrica - cono 24° con O'Ring - DIN 3865  
O'Ring metric female 24° cone - DIN 3865

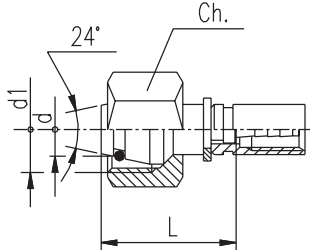

tubo tipo hose type 6400 -

6400			6500 - 6700		6500 - 6700	
Part. No.	L	d	p max.	Ch. d1	Part. no	p max.
801.40.006.00	21	6	315 bar	14 M12x1,5	804.40.006.00	315 bar
801.41.006.00	21	6	630 bar	17 M14x1,5	804.41.006.00	500 bar
801.40.008.00	21	8	315 bar	17 M14x1,5	804.40.008.00	315 bar
801.41.008.00	21	8	630 bar	19 M16x1,5	804.41.008.00	500 bar
801.40.010.00	21	10	315 bar	19 M16x1,5	804.40.010.00	315 bar
801.41.010.00	21	10	630 bar	22 M18x1,5	804.41.010.00	500 bar

Raccordo femmina metrica 90° - cono 24° con O'Ring - DIN 3865  
90° O'Ring metric elbow 24° cone - DIN 3865

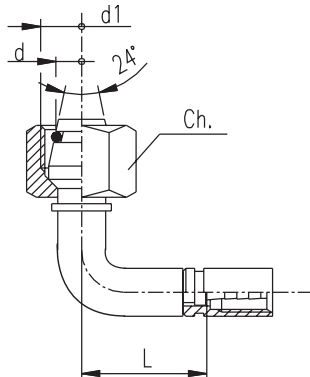

tubo tipo hose type 6400 -

6400			6500 - 6700		6500 - 6700	
Part. No.	L	d	p max.	Ch. d1	Part. no	p max.
801.42.006.00	27	6	315 bar	14 M12x1,5	804.42.006.00	315 bar
801.43.006.00	27	6	630 bar	17 M14x1,5	804.43.006.00	500 bar
801.42.008.00	27	8	315 bar	17 M14x1,5	804.42.008.00	315 bar
801.43.008.00	27	8	630 bar	19 M16x1,5	804.43.008.00	500 bar
801.42.010.00	27	10	315 bar	19 M16x1,5	804.42.010.00	315 bar
801.43.010.00	27	10	630 bar	22 M18x1,5	804.43.010.00	500 bar

## Raccorderia per tubi flessibili MCS

### Fittings for MCS micro-hose

#### Raccordo manometro

Secondo DIN 16288

#### Pressure gauge adapter

According to DIN 16288

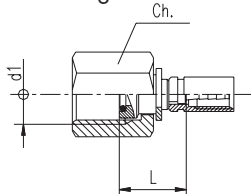

#### Raccordo manometro

Secondo ANSI/ASME B1.20.1

#### Pressure gauge adapter

According to ANSI/ASME B1.20.1

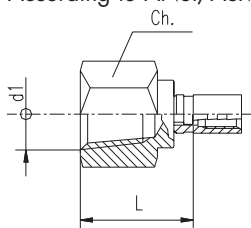

#### Raccordo femmina girevole "ORFS"

Secondo SAE J1453

#### Female swivel

According to SAE J1453

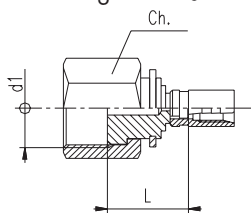

#### Raccordo femmina girevole 60°

Secondo BS 5200 / DIN 3863

#### 60° female swivel

According to BS 5200 / DIN 3863

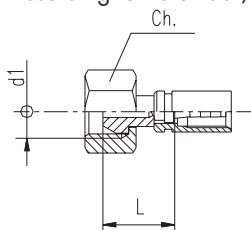

#### Raccordo femmina girevole

JIC 37° Secondo SAE J514

#### JIC 37° female swivel

According to SAE J514

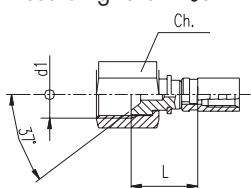

#### tubo tipo

#### hose type

6400				
Part. No.	L	d1	Ch.	p max.
801.50.204.00	15	ISO 228 G1/4"	17	630 bar
801.50.208.00	17	ISO 228 G1/2"	27	630 bar
801.50.112.00	17	M20 x 1,5	24	630 bar

#### tubo tipo

#### hose type

6400				
Part. No.	L	d1	Ch.	p max.
801.50.304.00	23	1/4"-18 NPTF	19	630 bar

#### tubo tipo

#### hose type

6400				
Part. No.	L	d1	Ch.	p max.
801.53.506.00	18	11/16-16 UN	22	400 bar

#### tubo tipo

#### hose type

6400				
Part. No.	L	d1	Ch.	p max.
801.60.202.00	14	ISO 228 G1/8"	14	630 bar
801.60.204.00	18	ISO 228 G1/4"	17	630 bar
801.60.141.00	18	M14 x 1,5	19	630 bar

#### tubo tipo

#### hose type

6400				
Part. No.	L	d1	Ch.	p max.
801.60.404.00	15	7/16"-20 UNF	14	450 bar
801.60.405.00	17	1/2"-20 UNF	16	420 bar

**Raccordo ad occhio diritto**

Secondo DIN 7642

**Straight banjo**

According to DIN 7642

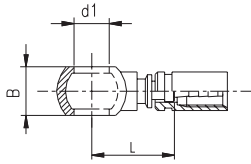

**Raccordo ad occhio a 90°**

Secondo DIN 7642

**90° banjo**

According to DIN 7642

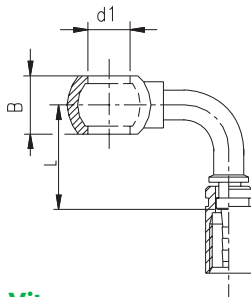

**Vite cava**

Secondo DIN 7643

**Screw for banjo**

According to DIN 7643

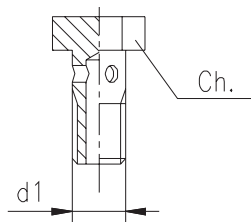

**Raccordo maschio fisso**

**Male fitting**

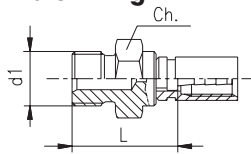

**Raccordo maschio fisso conico**

**Taper male fitting**

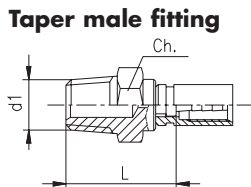

**Raccordo avvitabile**

**Nut connection**

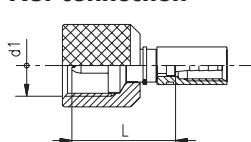

**tubo tipo hose type**

6400					6500 - 6700				
Part. No.	L	d1	B	p max.	Part. no	L	d1	p max.	
801.70.008.00	19	8	8	200 bar	804.70.008.00	19	8	200 bar	
801.70.010.00	21	10	10	200 bar	/	/	/	/	
801.70.202.00	21	1/8"	10	200 bar	/	/	/	/	

**tubo tipo hose type**

6400					6500 - 6700				
Part. No.	L	d1	B	p max.	Part. no	L	d1	p max.	
801.72.008.00	25	8	8	200 bar	804.72.008.00	19	8	200 bar	
801.72.010.00	22	10	10	200 bar	804.72.010.00	/	/	/	
801.72.202.00	22	1/8"	10	200 bar	/	/	/	/	

Part. No.	d1	Ch.
A38-08M	M8 x 1	12
A38-10M	M10 x 1	14
A39-A02	ISO 228 G1/8"	14

**tubo tipo hose type**

6400				
Part. No.	L	d1	Ch.	p max.
801.80.202.00	19	ISO 228 G1/8"	13	400 bar
801.80.204.00	24,5	ISO 228 G1/4"	19	630 bar

**tubo tipo hose type**

6400				
Part. No.	L	d1	Ch.	p max.
801.80.302.00	21	1/8"-27 NPTF	13	400 bar

**tubo tipo hose type**

6400				
Part. No.	L	d1	p max.	
801.10.125.00	22	S12.65x1,5	630 bar	

**Manometro digitale**  
**Digital pressure gauge**

---



## Dati tecnici e dimensioni Technical data and dimension

### Modello DG2 Model DG2

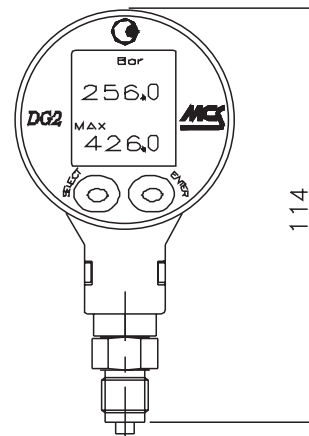
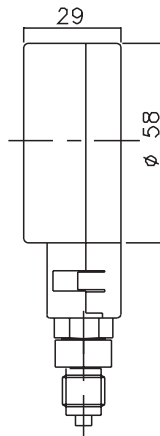

### Protezione urti Shock protection

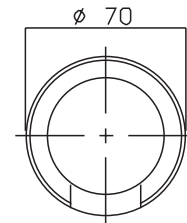
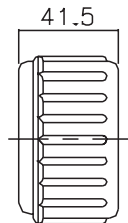

### Campo di misura

### Risoluzione

### Precisione totale\*

Pressure range	Resolution	Total accuracy*
-1.....3 bar	1 mbar	typ. 4 mbar max 6 mbar
-1....30 bar	10 mbar	typ. 30 mbar max 60 mbar
0...300 bar	100 mbar	typ.0,3 bar max 0.6 bar
0...700 bar	200 mbar	typ.0,7 bar max 1.4 bar

\* Include: linearità, ripetibilità, isteresi, errore di temperatura e risoluzione display

\* Include: linearity, repetibility, histeresys, temperature error and display resolution

Precisione	Accuracy	0.1% FStyp. ÷ 0.2% FSmax
Temperatura di stoccaggio	Storage temperature	-30...80°C
Campo di temperatura compensata	Compensated temperature range	0...50°C
Protezione CEI 529	Protection CEI 529	IP65
Connessione filettata	Pressure connection	1/4" Gas DIN 16288
Peso	Weight	125 g

### Modello DG1 Model DG1

Come DG2 con funzione di memoria picco massimo. Campionamento 5000 hz  
Similar as DG2 but whitin 5000 hz sample rate

### Esempio per l'ordinazione

### Order example

\_\_\_\_\_ Tipo 1 o 2  
 DG X - XXX \_\_\_\_\_ Campo di misura  
 (003/030/300/700)

\_\_\_\_\_ Type 1 or 2  
 DG X - XXX \_\_\_\_\_ Pressure range  
 (003/030/300/700)

**Manometri a bagno di glicerina**  
**Glycerine filled pressure gauges**

---

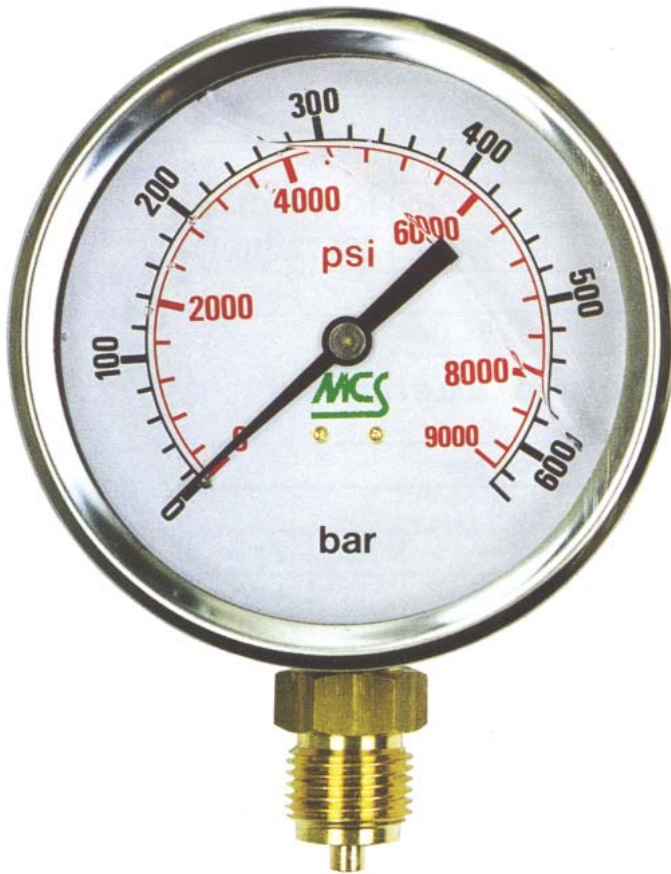



**Attacco radiale**  
**Bottom connection**

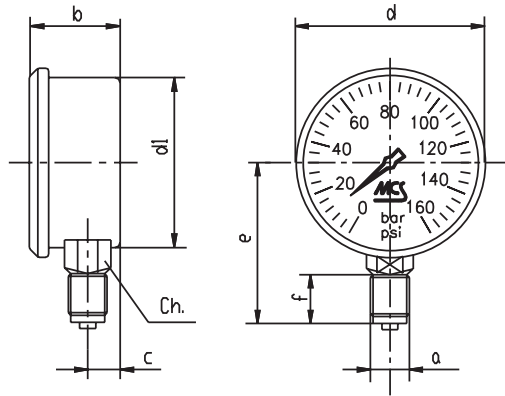

**Quote**      **Dimensions**

Tipo	Type	DN	a	b	c	d	d1	e	f	Ch.
7211		63	ISO 228 1/4"G	31	10	69	63	51	12	14
7211		100	ISO 228 1/2"G	47	17	105	100	80	18	22

**Attacco posteriore**  
**Back connection**

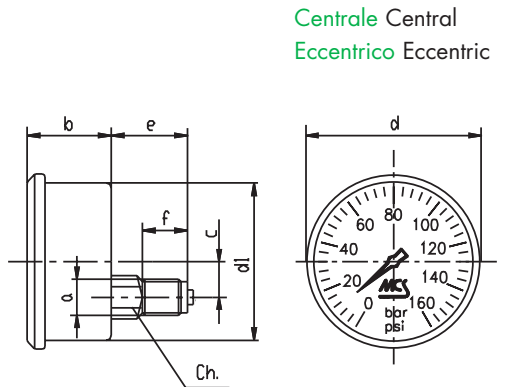

Centrale Central  
Eccentrico Eccentric

**Quote**      **Dimensions**

Tipo	Type	DN	a	b	c	d	d1	e	f	Ch.
7214		63	ISO 228 1/4"G	31	19	69	63	22	12	14
7215		100	ISO 228 1/2"G	37,5	31	105	100	35	18	22

**Attacco posteriore con flangia**  
**Back connection with front fixing flange**

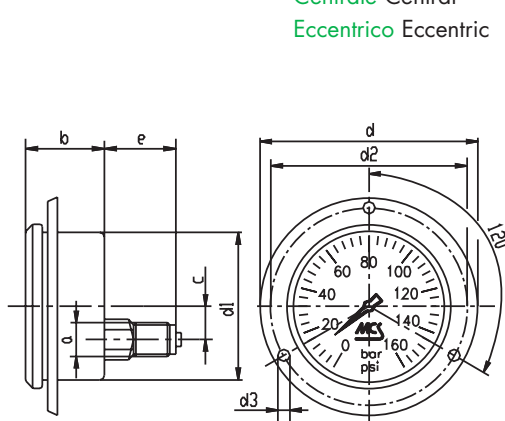

Centrale Central  
Eccentrico Eccentric

**Quote**      **Dimensions**

Tipo	Type	DN	a	b	c	d	d1	d2	d3	e
7216		63	ISO 228 1/4"G	31	19	84	63	75	12	14
7218		100	ISO 228 1/2"G	37,5	31	132	100	116	18	35

## Tipi e dimensioni

### Type and dimensions

#### Attacco posteriore con staffa di fissaggio

#### Back connection with clamp

#### Quote

Tip	Type	DN	a	b	c	d	d1	Ch.	f
7217		63	ISO 228 1/4"G	31	5	83	71	22	6,6

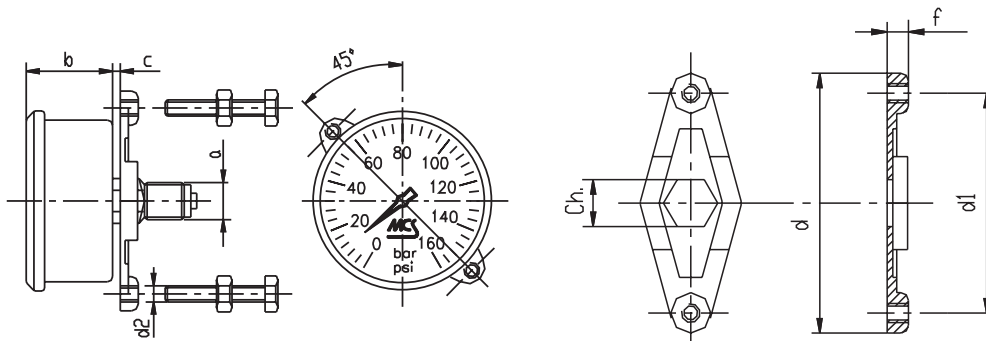

#### Attacco posteriore con staffa di fissaggio

#### Back connection with clamp

#### Quote

Tip	Type	DN	a	b	e	d1	d2	c	f	q
7219		100	ISO 228 1/2"G	37,5	35	100	M5	25	63	108

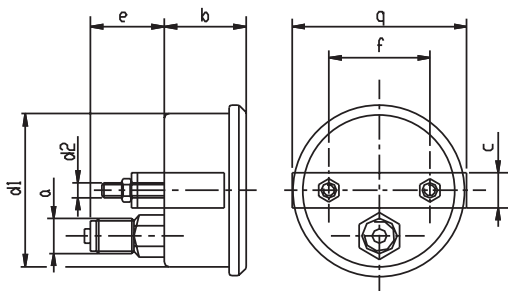

## Esempio per l'ordinazione

### Order example

#### Scale Ranges

bar	psi
0-6 bar	85 psi
0-10 bar	140 psi
0-25 bar	350 psi
0-40 bar	550 psi
0-60 bar	850 psi
0-100 bar	1400 psi
0-160 bar	2300 psi
0-250 bar	3500 psi
0-400 bar	5500 psi
0-600 bar	8500 psi

#### Codice

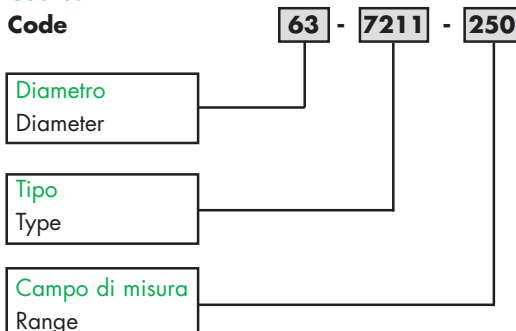

**Caratteristiche tecniche**

<b>Pressione d'esercizio:</b>	Stabile: 75% del valore di fondoscala
<b>Temperatura d'utilizzo:</b>	Ambiente: -25°C a 65°C
<b>Sovrapressione:</b>	25% ≤ 100 bar ; 15% > 100 bar
<b>Costruzione:</b>	cassa in acciaio inox riempita di glicerina con valvola di sfianto
<b>Fascia bordata:</b>	in acciaio inox AISI 304
<b>Flangia di fissaggio:</b>	in acciaio inox AISI 304 con tre fori
<b>Quadrante:</b>	in alluminio a sfondo bianco, con graduazione e numerazione in nero e rosso Marchio MCS in verde
<b>Indice:</b>	in alluminio laccato nero
<b>Vetro:</b>	in policarbonato trasparente
<b>Attacco:</b>	in ottone per pressioni da 0 a 600 bar con strozzatura interna da 0,8 mm
<b>Molla tubolare:</b>	- in bronzo fosforoso con saldature dolci per pressioni fino a 600 bar - in acciaio al Cr-Ni con saldature forti per pressioni da 600 a 1000 bar
<b>Dimensioni nominali e tipi di montaggio:</b>	a norme EN 837
<b>Precisione di misura a 20°C:</b>	- ± 1,6% v.f.s. per manometri ø 63 UNI 8293 e DIN 16005 - ± 1% v.f.s. per manometri ø100 UNI 8293 e DIN 16005
<b>Grado di protezione:</b>	IP 65 secondo EN 837
<b>Graduazione e numerazione:</b>	secondo EN 837

**Technical data**

<b>Working pressure:</b>	Steady: 75% of full scale value
<b>Working temperature range:</b>	Ambient: -25°C to 65°C / -40°F to 150°F
<b>Overpressure:</b>	25% ≤ 100 bar ; 15% > 100 bar
<b>Casing body:</b>	glycerine filled in stainless steel case with safety vent.
<b>Band ring:</b>	stainless steel AISI 304
<b>Fixing flange:</b>	stainless steel AISI 304 with 3 holes
<b>Dial:</b>	white painted aluminium with indelible black and red graduation MCS green mark
<b>Needle:</b>	black painted aluminium
<b>Transparent cover:</b>	polycarbonat
<b>Connection:</b>	brass for pressure up to 600 bar
<b>Tubular spring:</b>	in phosfor bronz for pressure up to 600 bar Cr-Ni steel for pressure up to 1000 bar
<b>Dimensions and assembly:</b>	according to EN 837
<b>Accuracy with temperature 20°C:</b>	+/- 1,6% referred to full scale value ø 63 UNI 8293 and DIN 16005 +/- 1% referred to full scale value ø 100 UNI 8293 and DIN 16005
<b>Protection class:</b>	IP 65 according to EN 837
<b>Range and graduation:</b>	according to EN 837

## Valigetta in metallo per controllo pressioni

### Metal test box for pressure check



► Costruzione in lamiera d'acciaio

► Verniciatura a forno resistente agli urti

► Coperchio sfilabile comprendente manometri a bagno di glicerina

► Vano per microtubi protetto da coperchio in lamiera d'acciaio

► Serie di microtubi lunghezza 2000 mm

► Dimensioni: 420 x 110 x 310 mm

► Construction: sheet-steel

► Shock resistant oven-baked painting

► Removable cover comprising glycerine-filled pressure gauges

► Box for micro-hoses protected by a sheet-steel cover

► 1 set of micro-hoses with length 2000 mm

► Dimensions: 420 x 110 x 310 mm

#### Doppia scala

#### Double scale BAR-PSI

0 - 10 bar

0 - 25 bar

0 - 40 bar

0 - 60 bar

0 - 100 bar

0 - 160 bar

0 - 250 bar

0 - 400 bar

0 - 600 bar

**Modello 750 N.63.00**

**Model 750 N.63.00**

**4 manometri ø 63 mm**

+ 4 microtubi con terminali M 16 x 2  
peso: 9,5 kg

**4 pressure gauges ø 63 mm**

+ 4 micro-hoses with terminals  
M 16 x 2  
weight: 9,5 kg



**Modello 750 N.63.10**

**Model 750 N.63.10**

**2 manometri ø 63 mm +  
2 ø 100 mm**

+ 4 microtubi con terminali M 16 x 2  
peso: 10,5 kg

**2 pressure gauges ø 63 mm +  
2 ø 100 mm**

+ 4 micro-hoses with terminals  
M 16 x 2  
weight: 10,5 kg



**Modello 750 N.63.00.7**

**Model 750 N.63.00.7**

**7 manometri ø 63 mm**

+ 7 microtubi con terminali M 16 x 2  
peso: 11 kg

**7 pressure gauges ø 63 mm**

+ 7 micro-hoses with terminals  
M 16 x 2  
weight: 11 kg



**Valigetta in plastica per controllo pressioni**  
**Plastic test box for pressure check**

---



**Modello 750.KP1****Model 750.KP1**

1 Valigetta in plastica	KP1	1 Plastic box	KP1
2 Manometri a bagno di glicerina	∅ 63	2 Glycerine-filled pressure gauges	∅ 63
1 Microtubo	6400-10.162-50.204-2000 mm	1 Micro-hose	6400-10.162-50.204-2000 mm
Dimensioni	240 x 200 x 40 mm	Dimensions	240 x 200 x 40 mm

**Modello 750.KP2****Model 750.KP2**

1 Valigetta in plastica	KP2	1 Plastic box	KP2
2 Manometri a bagno di glicerina	∅ 63	2 Glycerine-filled pressure gauges	∅ 63
2 Miniprese di pressione	620.01.204.21	2 Test points	620.01.204.21
1 Microtubo	6400-10.162-10.162-2000 mm	1 Micro-hose	6400-10.162-10.162-2000 mm
2 Portamanometri	620.08.204.00	2 Pressure gauge connections	620.08.204.00
1 Portamanometro presa diretta	620.09.204.00	1 Pressure gauge adapter	620.09.204.00
1 Riduzione	630.01.206.10	1 Reducer	630.01.206.10
1 Riduzione	630.01.208.20	1 Reducer	630.01.208.20
1 Minipresa	620.01.008.01	1 Test point	620.01.008.01
1 Minipresa	620.01.010.01	1 Test point	620.01.010.01
Dimensioni	390 x 200 x 80	Dimensions	390 x 200 x 80

**Modello 750.KP2.DGX.XXX.(XXX)****Model 750.KP2.DGX.XXX.(XXX)**

1 Valigetta in plastica	KP2	1 Plastic box	KP2
1(2) Manometro	DGx.xxx	1(2) Pressure gauge	DGx.xxx
1 Minipresa di pressione	620.01.204.21	1 Test point	620.01.204.21
1 Minipresa di pressione	620.01.014.21	1 Test point	620.01.014.21
1 Minipresa di pressione	620.01.008.01	1 Test point	620.01.008.01
1 Minipresa di pressione	620.01.010.01	1 Test point	620.01.010.01
1 Riduzione	630.01.206.20	1 Reducer	630.01.206.20
1 Riduzione	630.01.208.20	1 Reducer	630.01.208.20
1 Portamanometro presa diretta	620.09.204.00	1 Pressure gauge adapter	620.09.204.00
1(2) Microtubo	6400-10.162-50.204-1000	1 Micro-hose	6400-10.162-50.204-1000
Dimensioni	390 x 260 x 80 mm	Dimensions	390 x 260 x 80 mm

**Esempio per l'ordinazione**

\_\_\_\_\_ Tipo 1 o 2  
 \_\_\_\_\_ Campo di misura I° manometro  
 DG X - XXX - (XXX) — Campo di misura II° manometro  
 (003/030/300/700)

**Order example**

\_\_\_\_\_ Type 1 or 2  
 \_\_\_\_\_ Pressure range I° gauge  
 DG X - XXX - (XXX) — Pressure range II° gauge  
 (003/030/300/700)



**OLEOTEC S.r.l.**

Via Dalmazia 55

21100 VARESE - ITALY

Tel. ++39 0332-331238

Fax ++39 0332-331622

mail@oleotec.it • www.oleotec-srl.com